

ISUZU EXR52 & EXZ52

Heavy - Duty Forward Control Trucks

EURO 4
Approved

DIMENSIONS & MASS

units: mm

MODEL	GCM (kg)	WB	OAL	FOH	ROH	CE	CA	OW	AW	CW	OH	HH	EH	TIRE SIZE		TURNING RADIUS
														FRONT	REAR	
EXR52E	50000	3450	5821	1400	971	3671	2700	2490	2065	1850	2970	225	1130	295/80R22.5	295/80R22.5	6200
EXZ52K	80000	4535	6626	1400	1346	4476	2475	2490	2065	1850	2970	250	1150	295/80R22.5	295/80R22.5	7300

EXR52 (4X2)

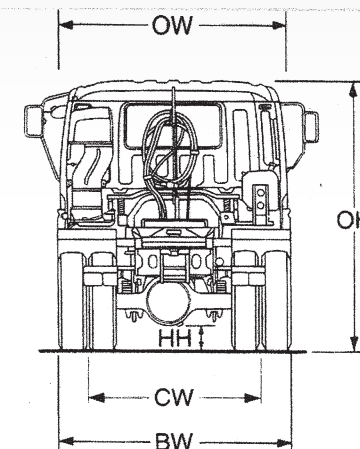
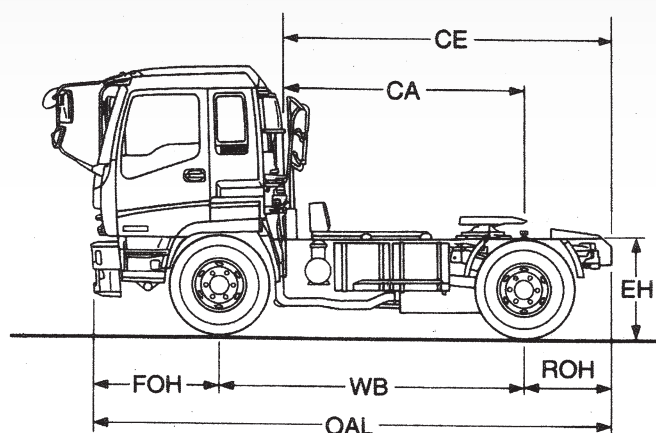
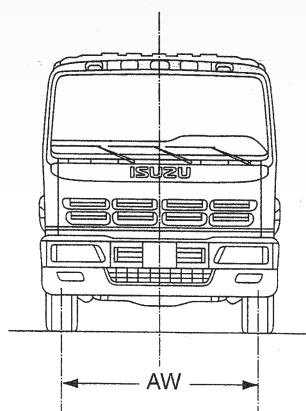

EXZ52 (6X4)

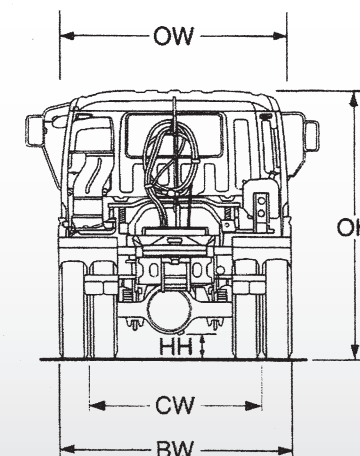
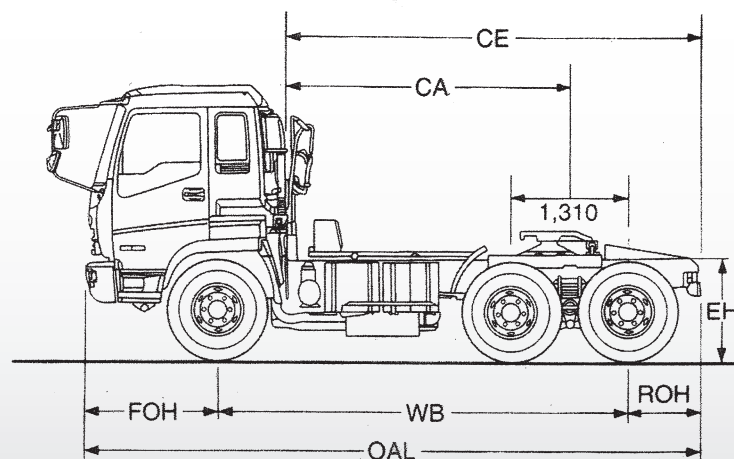
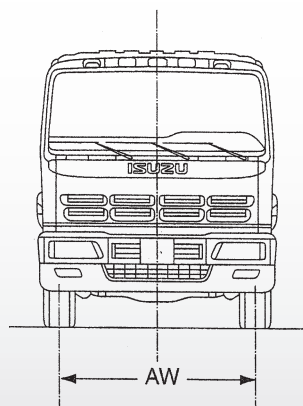

TECHNICAL SPECIFICATIONS

Model	EXR52E	EXZ52K
Drive System	4x2	6x4
Gross Combination Mass (GCM) Kg	50000	80000

ENGINE

Engine Type	6WG1-TC	
	4 Cycle, 6 In-Line SOHC, Common Rail Electronic Controlled Injection, Water-Cooled, VGS Turbo Charger, Intercooler, EGR	
No. of Cylinders	Six (6)	
Displacement (cc)	15681	
Bore x Stroke (mm)	147 x 154	
Compression Ratio	16.5 : 1	
Max. output Kw(PS)/ rpm	294 (400) / 1800	
Max. torque Nm(kgm)/ rpm	1765 (180) / 1300	
Emission standard	EURO 4	

CHASSIS

Transmission	Type Option	MJ7S - 7 Speed Overdrive		
		Automatic Mechanical Transmission or Full-automatic Transmission		
Final Gear	Type	Single Reduction Hypoid Gear		
	Ratio	4.875		
Brakes	Service	Full Air with Dual Circuit and Anti-locking brake (ABS)		
	Front	Drum		
	Rear	Drum		
	Parking	Spring actuator at Rear wheels	Spring actuator at Rearward Rear wheels	
	Auxiliary	Exhaust brake electro-pneumatic control with butterfly valve in exh pipe		
Steering	Type	Recirculating Ball Nut Type with integral power assisted		
	Gear Ratio	17.9 : 1		
Axle	Front	Type	Reverse Elliot I Beam	
		Capacity	7500	7500
	Rear	Type	Banjo, Fully Floating	Tandem Drive with Interlocking
		Capacity	13000	21500
Suspension	Front	Semi-elliptical Alloy Steel Leaf Spring with hydraulic shock absorber		
	Rear	Semi-elliptical alloy steel spring	Trunnion type semi-elliptical alloy steel leaf spring	
Frame	Type	Ladder Type Channel Section		
Wheels & Tires	Disc Wheel	22.5 x 8.25 (8 studs)		
	Front	295/80R22.5		
	Rear (Dual)	295/80R22.5		
Electrical System	Battery	12V - 120AH x 2pcs		
	Alternator	24V - 50A		
	Starter	24V - 7.0Kw		
Fuel Tank	Capacity	300 Litres, 200 Litre x 2		
Cab	Type	Air Suspension Tilt Cab		
	Capacity	1 Driver & 2 Passengers		

合眾汽車私人有限公司



TRIANGLE AUTO PTE LTD (A Subsidiary of Dah Chong Hong Ltd)

Email: sales@triangleauto.com.sg Website: www.triangleauto.com.sg

- 20 Tuas Ave 2 Tel: 6861-6800 Fax: 6861-6900 Weekdays: 8.30am - 5.30pm, Sat: 8.30am - 4.30pm
- 61 Ubi Ave 2 #01-18 Automobile Megamart Tel: 6848-4300/6744-6300 Open Daily: 10am - 6.30pm